

BRASS BALL VALVE WITH REDUCTION GEAR**SINCERT**

Size : DN 3/8" to 2"1/2
Ends : Female BSP
Min Temperature : - 10°C
Max Temperature : + 90°C
Max Pressure : 40 Bars (up to DN1")
Specifications : Anti blow out stem
Reduction gear (slow opening or closing)
Full bore

Materials : Brass

BRASS BALL VALVE WITH REDUCTION GEAR

SPECIFICATIONS :

- Reduction gear (slow opening or closing), 1 tour for opening or closing
- Full bore
- Anti blow-out stem
- Solid ball
- With O ring on stem

USE :

- For all common fluids
- Min Temperature Ts : - 10 °C
- Max Temperature Ts : + 90°C
- Max Pressure Ps : 40 bars up to DN1", 25 bars over (see graph under)

PRESSURE / TEMPERATURE GRAPH (STEAM EXCLUDED) :

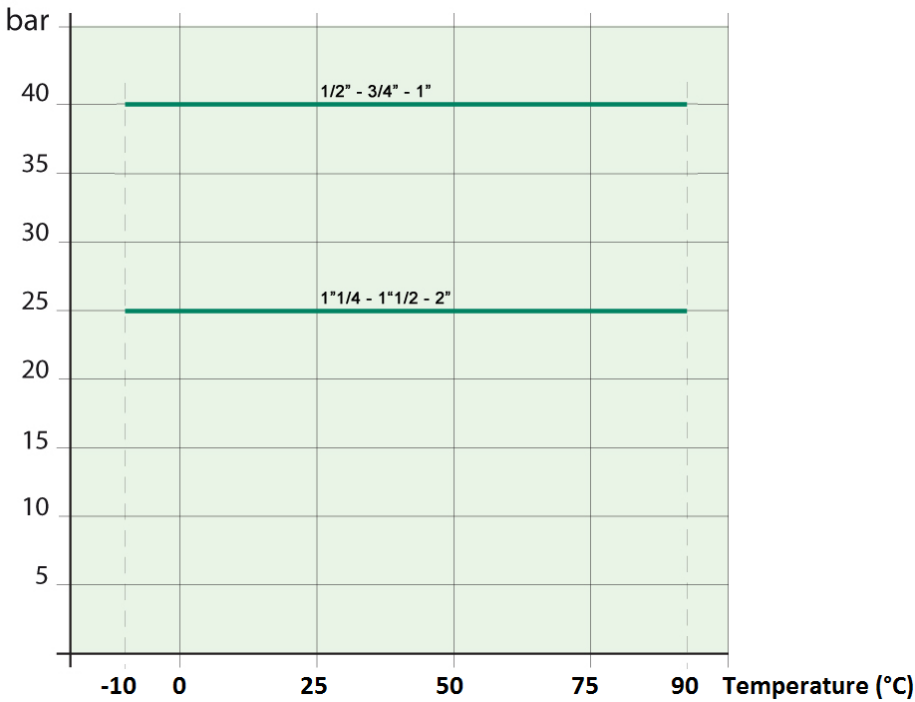

RANGE :

- Female / Female threaded BSP with reduction gear **Ref. 531** from DN 3/8" to 2"1/2

BRASS BALL VALVE WITH REDUCTION GEAR

FLOW COEFFICIENT Kvs (M3 / h) :

DN	3/8"	1/2"	3/4"	1"	1"1/4	1"1/2	2"	2"1/2
Kvs (m3/h)	15	20	45	60	100	170	265	510

HEAD LOSS GRAPH :

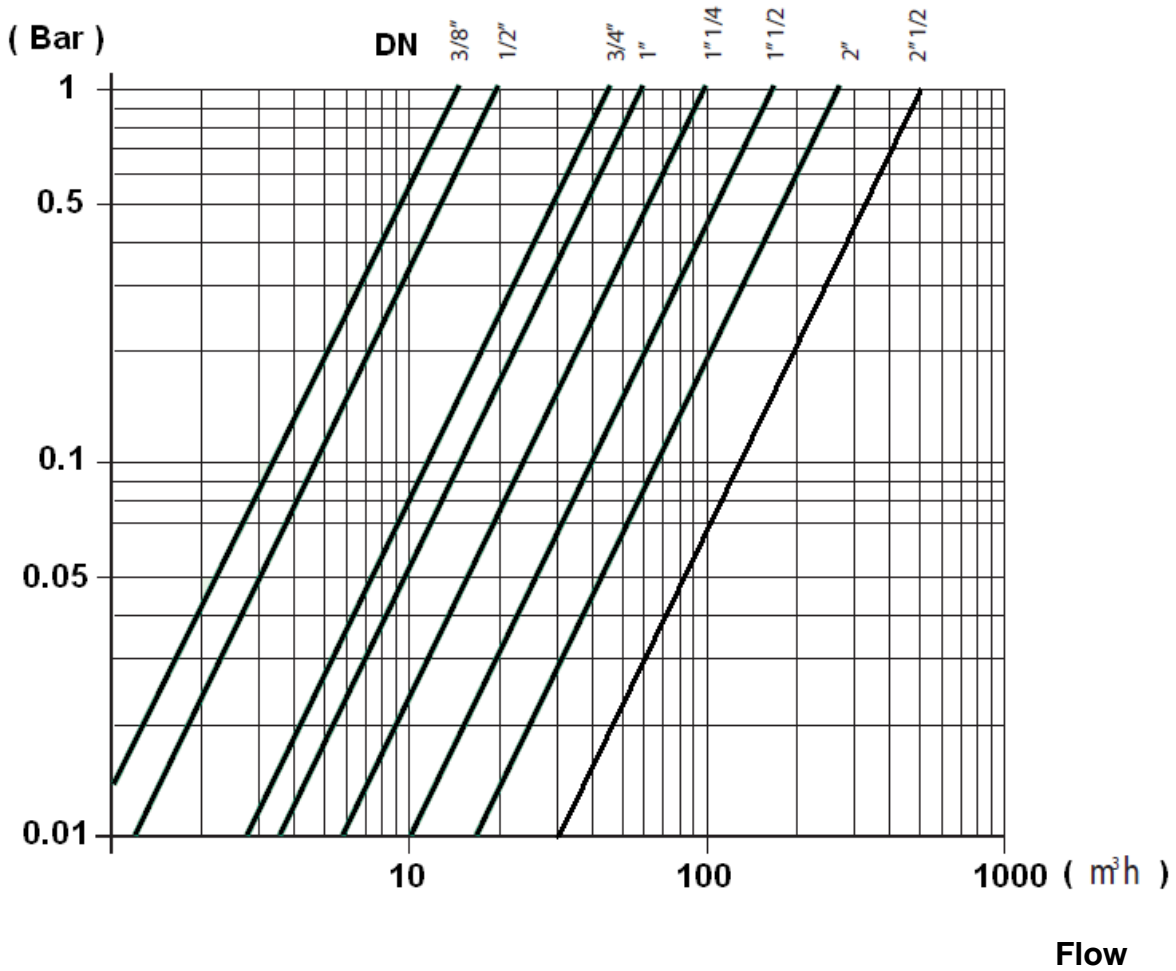

BRASS BALL VALVE WITH REDUCTION GEAR

MATERIALS :

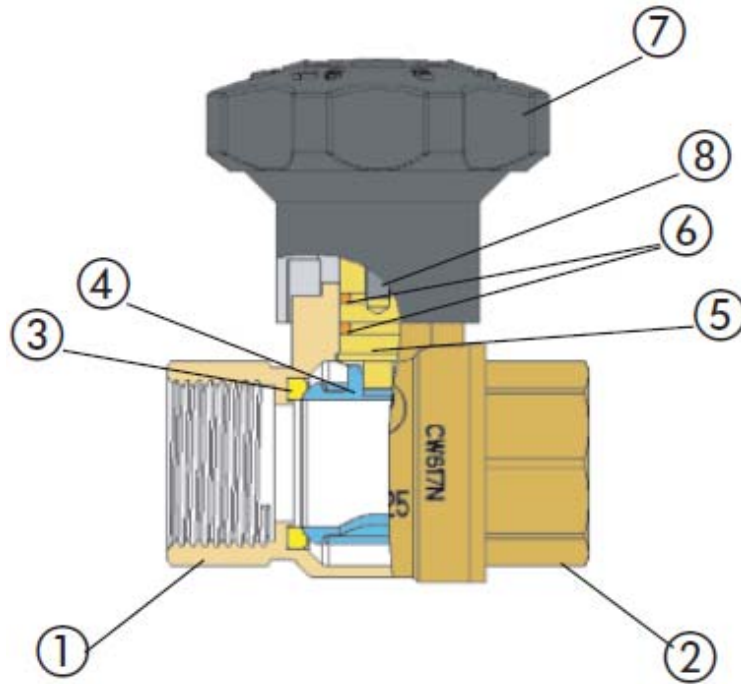

Item	Designation	Materials
1	Body	Nickeled brass CW 617 N according to EN 12165
2	Mamelon	Nickeled brass CW 617 N according to EN 12165
3	Seat	PTFE
4	Ball	Chromed brass CW 617 N according to EN 12165
5	Stem	Brass CW 614 N according to EN 12164
6	O ring	NBR
7	Reduction gear	Nylon
8	Screw	Steel

BRASS BALL VALVE WITH REDUCTION GEAR

SIZE (in mm) :

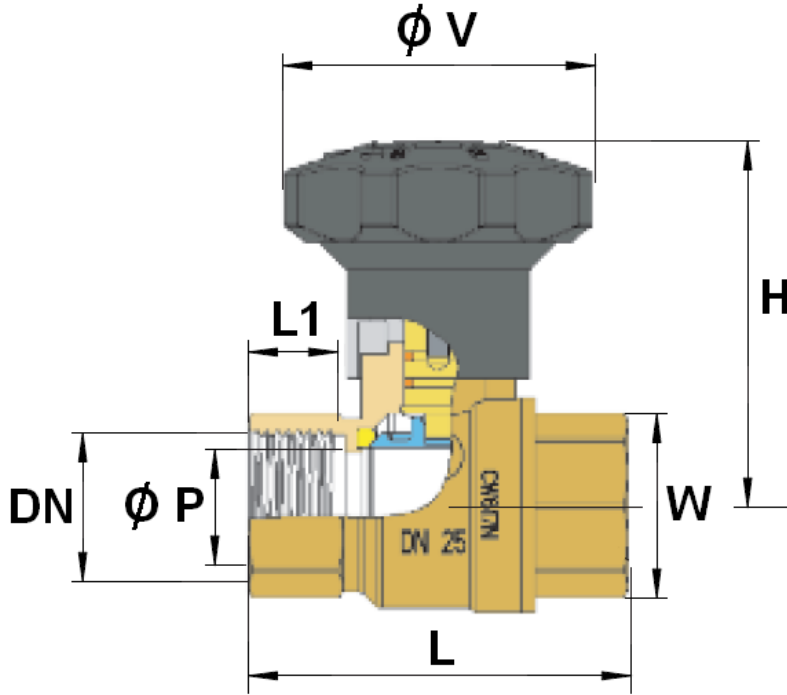

Ref.	DN	3/8"	1/2"	3/4"	1"	1"1/4"	1"1/2"	2"	2"1/2"
531	Ø P	16	15	20	25	32	40	50	61
	L	60	63	71	83	92	104	124	140
	L1	10	15	16	19	21	21	26	26
	H	58	66	68	75	80	109	115	168
	Ø V	70	70	70	70	70	112	112	112
	W on flat	22	26	31	38	48	55	68	85
	Weight (Kg)	0.20	0.28	0.36	0.56	0.83	1.36	2.14	3.85

BRASS BALL VALVE WITH REDUCTION GEAR

WORKING POSITIONS :

- **Opened valve**

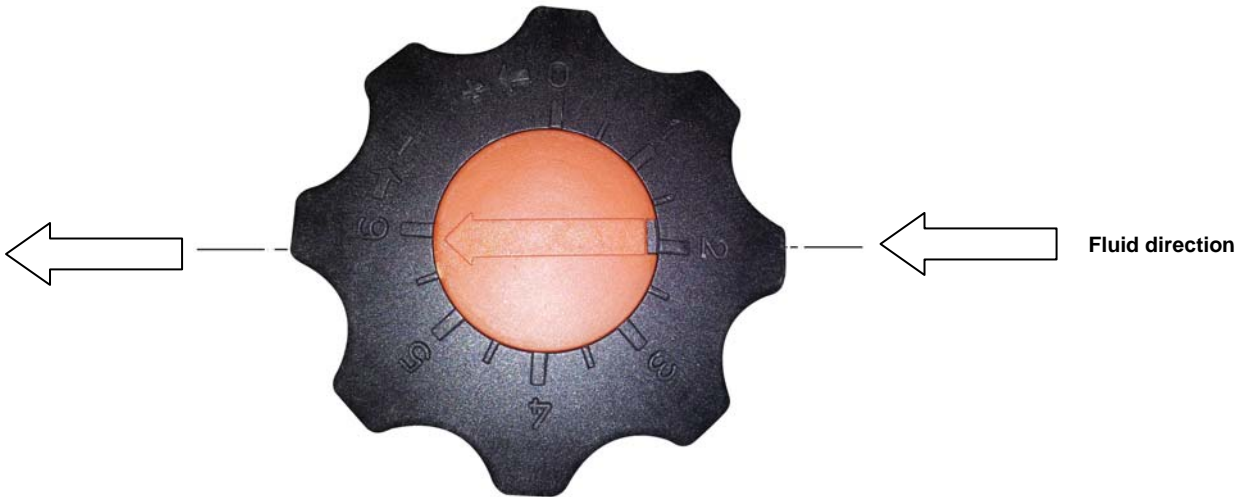

- **Closed valve**

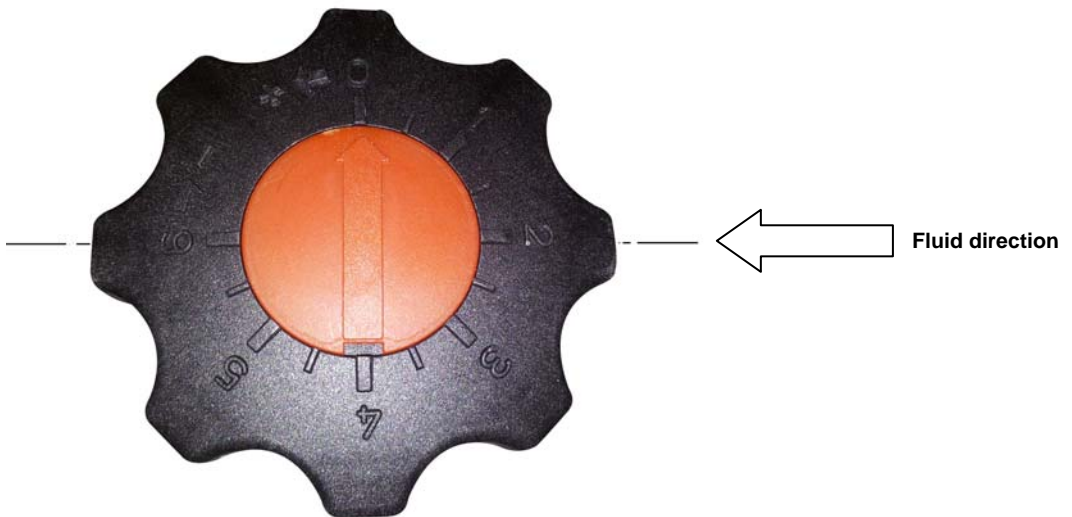

BRASS BALL VALVE WITH REDUCTION GEAR**STANDARDS :**

- Fabrication according to ISO 9001 : 2008
- DIRECTIVE 97/23/CE : Products excluded from directive up to DN1" (Article 3, § 3)
Risk category I module A from DN1 "1/4 to DN2"
- Threaded female BSP cylindrical according to ISO 7/1 Rp

ADVICE : Our opinion and our advice are not guaranteed and SFERACO shall not be liable for the consequences of damages.
The customer must check the right choice of the products with the real service conditions.

BRASS BALL VALVE WITH REDUCTION GEAR**INSTALLATION INSTRUCTIONS****GENERAL GUIDELINES :**

- Ensure that the valves to be used are appropriate for the conditions of the installation (type of fluid, pressure and temperature).
- Be sure to have enough valves to be able to isolate the sections of piping as well as the appropriate equipment for maintenance and repair.
- Ensure that the valves to be installed are of correct strength to be able to support the capacity of their usage.
- **Installation of all circuits should ensure that their function can be automatically tested on a regular basis (at least two times a year).**

INSTALLATION INSTRUCTIONS :

- **Before installing the valves, clean and remove any objects from the pipes** (in particular bits of sealing and metal) which could obstruct and block the valves.
- **Ensure that both connecting pipes either side of the valve (upstream and downstream) are aligned (if they're not, the valves may not work correctly).**
- **Make sure that the two sections of the pipe (upstream and downstream) match, the valve unit will not absorb any gaps. Any distortions in the pipes may affect the tightness of the connection, the working of the valve and can even cause a rupture.** To be sure, place the kit in position to ensure the assembling will work.
- Before starting the fitting, ensure that the threads and tapping are clean.
- **If sections of piping do not have their final support in place, they should be temporarily fixed. This is to avoid unnecessary strain on the valve.**
- The theoretical lengths given by ISO/R7 for the tapping are typically longer than required, the length of the thread should be limited, and **check that the end of the tube does not press right up to the head of the thread.**
- For the sealing assembly valve piping, it is essential to use products that are compatible with the requirements of the French water agreement ACS : **plumbers hemp proscribed.**
- Position the pipe clips on both sides of the valve.
- If mounting on an air conditioning with PER tubing and hoses, it is necessary to support the tubes and hoses with the fixing to avoid strain on the valve.
- When screwing the valve, ensure that you only rotate on screwed side by the 6 ended side. Use an open ended spanner or an adjustable spanner and not a monkey wrench.
- **Never use a vice to tighten the fixings of the valve.**
- Do not over tighten the valve. Do not block with any extensions as it may cause a rupture or weakening of the casing.
- **In general, for all valves used in buildings and heating, do not tighten above a torque of 30 Nm.**

The advice and assembly instructions above do not conform to any guarantee.
The information is given in general. It states what must not and must be done.
It is provided to ensure the safety of the personnel and the reliability of the valves.
The instructions in bold must be followed.